

# Virgola

## STRUCTURAL FEATURES

### PRODUT SHEET

FRONTS in \*multi-plywood curved thickness 12 mm faced with vertical grain wood veneer.

SIDE PANELS and TOP in medium density \*wood thickness 10 mm always faced with vertical grain wood veneer. Tops are also available in ceramic thickness 12 mm or glossy or satin lacquered glass thickness 10 mm.

INTERNAL STRUCTURE in \*wood particle board panel thickness 20 mm.

TOUR DRAWER thickness 12 mm and BOTTOM thickness 8 mm in \*wood panels with Sketch Roccia melamine.

First drawer opening by upper band between top and front. Other drawers open with Push-pull opening.

\*Wood and derivatives components according to the following standards: E1-TSCA-CARB-UBA.

### RUNNERS FOR DRAWERS

Opening system for first drawer with high sliding metal runners with FULL EXTRACTION, end-of-run buffer with dynamic capacity of 30 kg. "Blumotion" soft-closing mechanism integrated in the runner for a silence and soft closing system. For drawers with Push-pull opening, the runners are equipped with a synchronizer.



### BEDSIDE TABLE SECTION WITH BACKLIGHTING

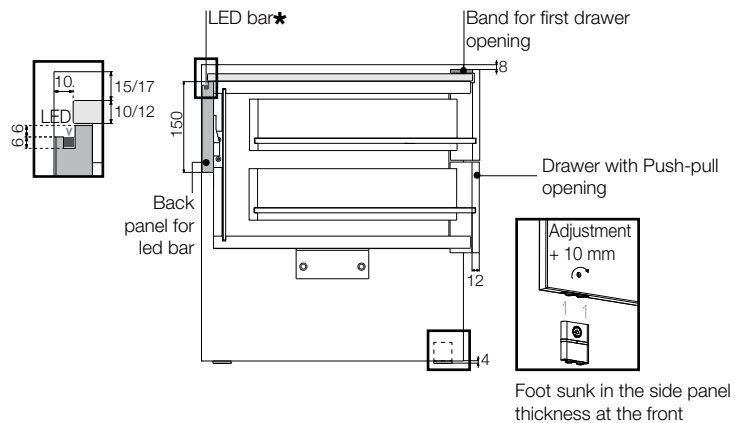

\* When there is no LED, the top is flush with the back panel.

Bedside table and drawer chest are delivered disassembled as in the diagram

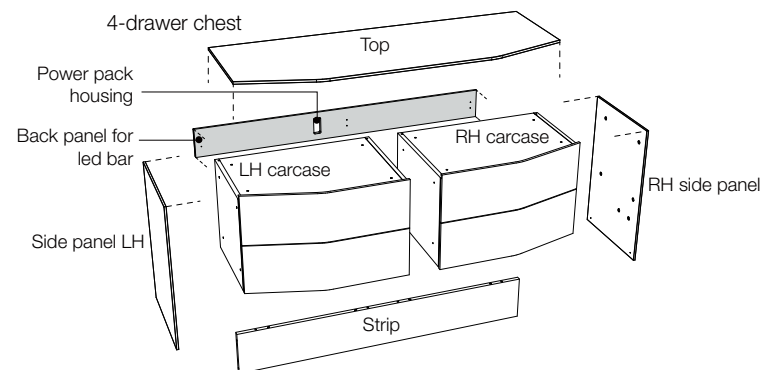

Bedside table with 2 drawers

