

PRODUCT DATA SHEET

STRUCTURE Thickness 20 mm, **TOP** Thickness 15 mm and **FRONTS** Thickness 35 mm in *wood particle board panels coated with synthetic melamine also matt, glossy lacquered or metal or with painted wood veneere. With "gloss front panel" we refer to the external side and its gloss edges, while the interior is supplied with the corresponding matt lacquered colour.

BACK PANELS in medium density *wood particle board panels thickness 4 mm with synthetic melamine.

TURN DRAWER thickness 12 mm and **BOTTOM** thickness 8 mm in *wood particle board panels with melamine Sketch Roccia.

Opening through a side groove in the same colour as the structure when lacquered or with the proposed combinations in all other cases.

Black ABS **FEET**, diam. 50 mm, height 27 mm, 12 mm adjustable from the inside.

*Wood and derivates components according to the following standards: E1-TSCA-CARB-UBA.

RUNNERS FOR DRAWERS

Opening with side grip: High sliding full extraction metal runners with **FULL EXTRACTION**, end-of-run buffer with dynamic capacity of 30 kg. "Blumotion" soft-closing mechanism integrated in the runner for a silence and soft closing system. Anti-tilting pin, vertical and inclination adjustment of fronts incorporated in all system runners. Additional stabilizer bar for drawers width 750 and 900 and "MOVENTO" runners with built-in stabilizer and also front side adjustment for drawers width 1200 and 1500.

DRAWER UNITS ARE DELIVERED WITH A NON-TILTING DEPTH ADJUSTMENT BRACKET TO BE FIXED TO THE WALL.

DRAWER UNITS WITH FEET H 27

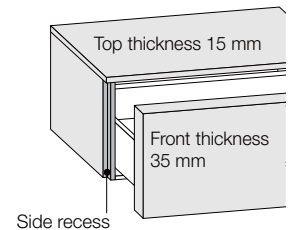
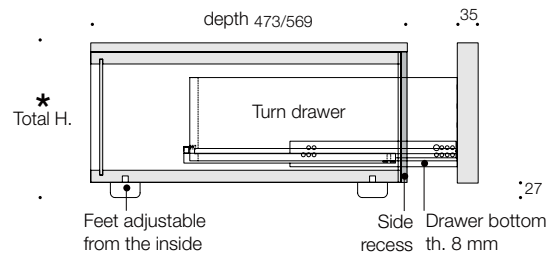

HANGING DRAWER UNITS

Valeo modules H 267 - H 347 can be provided with wall fixing brackets.

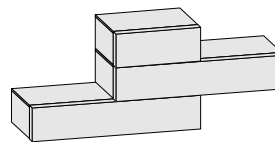

NOTE: The wall units cannot be hung one above the other but must be hung individually

Wall units W 450 - 600 - 750 - 900 with two brackets

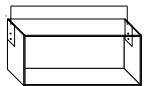

Wall units W 1200 - 1500 with 3 fixing brackets

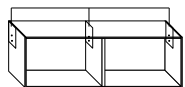

Adjacent wall units with four brackets

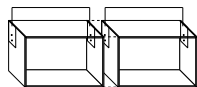

HANGER TYPE "B"

Shelf bracket attachment



Vertical adjustment 13 mm

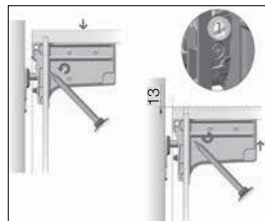

Horizontal adjustment 12 mm

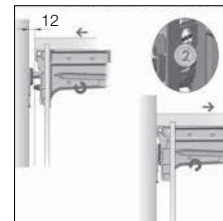

Anti-detachment element



FRONT ADJUSTMENT



CATAS CERTIFICATE according to the rules: TÜV - LGA

VERTICAL ADJUSTMENT



CAPACITY



ATTENTION : the capacity is related to the hardware mounted in the furniture. The given plugs for the wall mounting may not be suitable in certain situations. The responsibility concerning the assembly of the furniture belongs to the buyer, who must evaluate the resistance of his/her wall. The stability and capacity of wall-mounted elements are guaranteed by the proper assembly and by following our instructions correctly. The shelves inside the units are designed for the light loads typical of residential use (around 25 kg per square metre), distributed uniformly over the surface. For heavier or more concentrated loads, we recommend using single units with 300 - 375 - 450 - 600 mm width.

STRUCTURAL FEATURES

STRUCTURE OF MODULAR ELEMENTS WITH 1 DRAWER

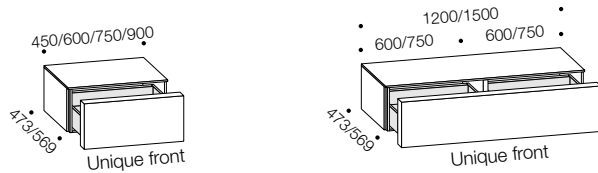

COMPARTMENTS OF UNITS WITH 2-3-6 DRAWERS

W 1200 with single surround, cover with warping bar and opening stabilizer mechanism.
Cover max capacity 10 kg

Drawer chest with 2 drawer units with full top

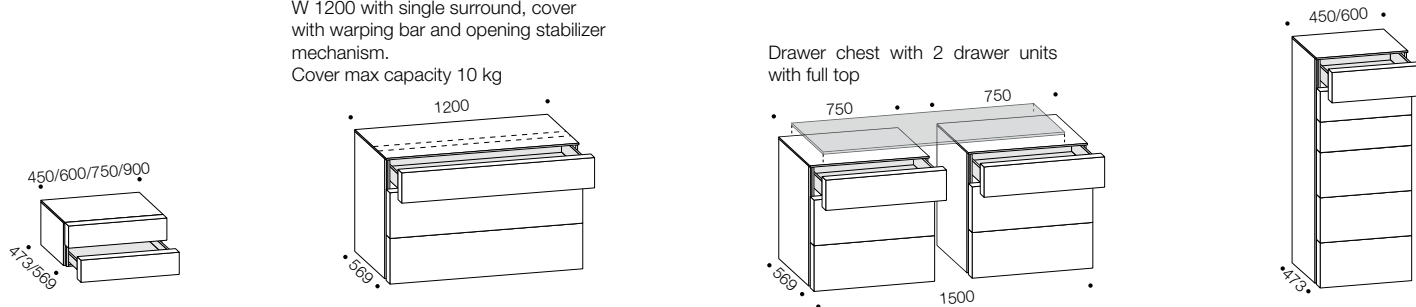

NOT ALIGNED SUPERIMPOSED DRAWER UNITS (FOR SELF-SUPPORTING COMPOSITIONS)

To ensure proper operation of the hardware, and to stop the structure from buckling, non-aligned side panels on superimposed units or internal divisions on those below or protruding on non-aligned or cantilever compositions must not exceed 225mm).

Compositions not within these parameters are provided with superimposed units with wall mounting hardware.

Modular units do not provide rovere trattato finish.

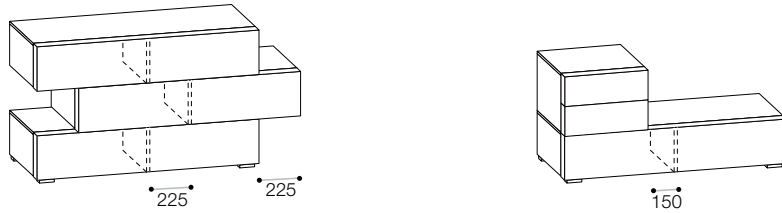

MATCHING THE SIDE RECESS GRIP WITH THE STRUCTURE

CARCASS:

Carbone OAK
Argilla OAK
Grigio OAK
Avana OAK
Cuba OAK
ROVERE NODATO Naturale
ROVERE NODATO Caramello
TERMOTRATTATO OAK
CANALETTO WALNUT

Matt LACQUERED
Glossy LACQUERED
Metal LACQUERED

MELAMINE Olmo Medio
MELAMINE Olmo Scuro
MELAMINE Loto Natura
MELAMINE Loto Tortora
MELAMINE Loto Terra
MELAMINE Sketch Sabbia
MELAMINE Sketch Roccia
MELAMINE Sketch Tabacco
MELAMINE Econoce

SIDE RECESS:

BROWN
Matt TERRANOVA
BROWN
Matt DUNE
BROWN
BROWN
BROWN
BROWN
BROWN

Matt LACQUERED
Glossy LACQUERED
Metal LACQUERED

Matt SILICE
BROWN
Matt GRIGIO CORDA
Matt GRIGIO CORDA
Matt TERRANOVA
Matt SAND
Matt SILICE
Matt CASTORO
BROWN