

Domino Units with drawers

Structural features

PRODUCT DATA SHEET

STRUCTURE AND FRONTS in medium density wood particle board panels * thickness 20 mm with 45°-shaped edges. Internal side and edges with synthetic melamine matt lacquered or meal. External side with the same finish or coated with painted wood veneer.

BACK PANELS in medium density *wood particle board panels thickness 8 mm with synthetic melamine also matt lacquered or metal.

TURN DRAWER thickness 12 mm and BOTTOM thickness 8 mm in *wood particle board panels with melamine Sketch Roccia.

Black ABS FEET, diam. 50 mm, height 27 mm, 12 mm adjustable form the inside.

SOSPENDO BASE SUPPORT consisting of black metal frame with shaped laser-cut steel feet finished with epoxy or liquid painting.

SHELVES in medium density *wood particle board panels thickness 10 mm with synthetic melamine matt lacquered or metal or coated with wood veneer. Shelves in fumé glass thickness 10 mm.

*Wood and derivates components according to the following standards: E1-TSCA-CARB-UBA.

RUNNERS FOR DRAWERS

Push-pull opening: High sliding full extraction metal runners with FULL EXTRACTION, end-of-run buffer with dynamic capacity of 30 kg. Integrated sliding synchronizer in drawer runners wider than 450. Anti-tilting pin, vertical and inclination adjustment of fronts incorporated in all system runners. Drawers width 1200 and 1500 with "MOVENTO" runners and side adjustment of fronts.

Opening system with Domino handle or with overlap: High sliding full extraction metal runners with FULL EXTRACTION, end-of-run buffer with dynamic capacity of 30 kg. "Blumotion" soft-closing mechanism integrated in the runner for a silence and soft closing system. Anti-tilting pin, vertical and inclination adjustment of fronts incorporated in all system runners.

Additional stabilizer bar for drawers width 900 and "MOVENTO" runners with built-in stabilizer and also front side adjustment for drawers width 1200 and 1500.

DRAWER UNITS NOT FINISHED ON BACK ARE PROVIDED WITH AN ADJUSTABLE DEPTH, NON-TILTING BRACKET TO ATTACH TO THE WALL.

Domino drawer units have a shaped structure with 45° joint to house the front frame, which also has 45° edges. The system is used for drawer sets with internal side panels or for superimposed or adjacent units. Superimposed or adjacent units can stand on the floor with H 27 feet.

Structure detail

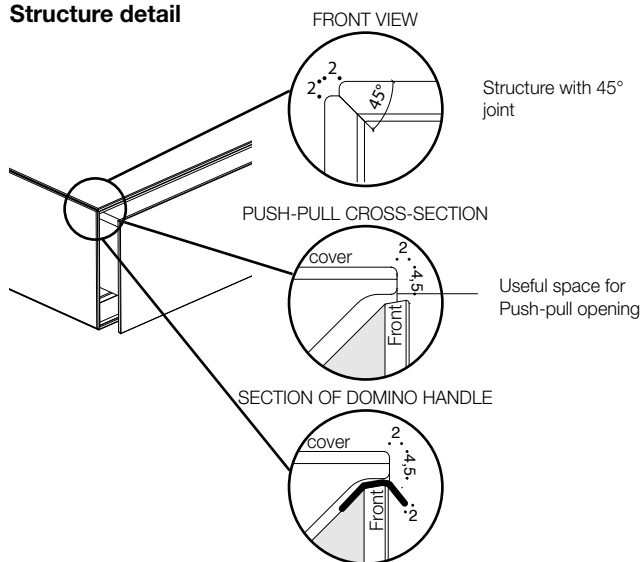

PUSH-PULL OPENING

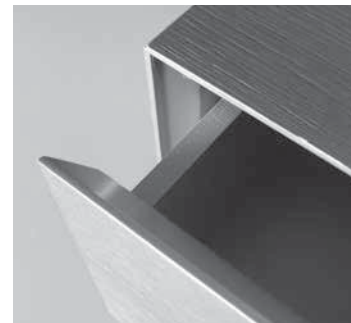

DOMINO HANDLE

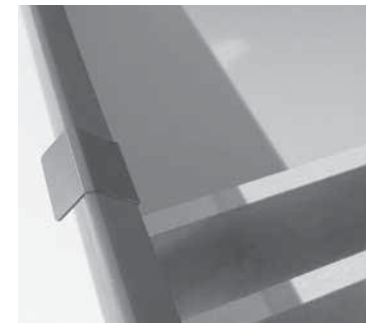

Finishes for Domino units

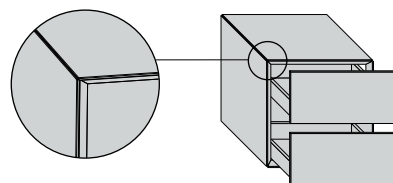

One-colour finish

Matt lacquered
Metal lacquered

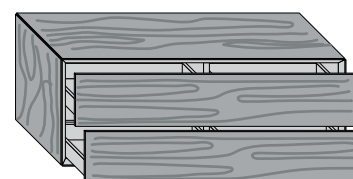

External finish

Internal finish

Carbone, Grigio, Avana, Argilla, Cuba veneered oak
Matt lacquered
Metal lacquered

Domino Units with drawers

Structural features

STRUCTURES FOR DRAWERS H150/225/300/375

are supplied already assembled and fitted with joining screws where necessary, complete with brackets for wall units and adjustable feet for floor-standing units.

STANDARD PUSH-PULL OPENING SYSTEM

DOMINO HANDLE (upon request with surcharge + € 20)

1 drawer

D	W
546	450-600-900
452	450-600-900

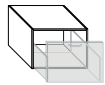

1 drawer W 1200 with full turn drawer, top panel with anti-warping bar and mechanism for opening stabilization.

Cover max capacity 10 kg

It is possible to overlap aligned drawer units with one drawer with the same width.

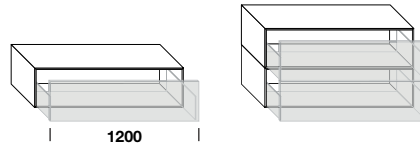

D	W
546	1200
452	1200

Double drawer with internal partition

D	W
546	1500-1800
452	1500-1800

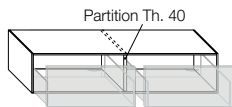

Full front with internal partition and double turn drawer UPON REQUEST.

It is possible to overlap drawer units to single or double turn drawer, also not aligned.

Press the centre of the front of this type of drawer to operate the push-pull mechanism.

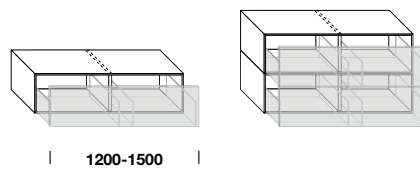

D	W
546	1200-1500
452	1200-1500

STRUCTURES FOR UNITS WITH UPPER OPEN COMPARTMENT

OPENING WITH UPPER OVERLAP

For drawers or deep drawers

CROSS-SECTION

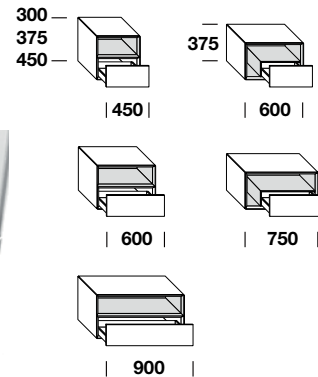
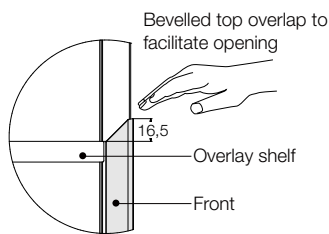
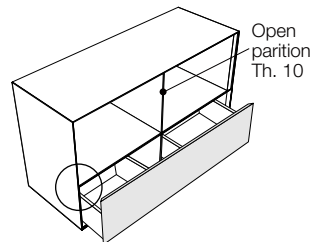

DOMINO
UNITS WITH
DRAWERS

STRUCTURES FOR UNITS WITH SIDE OPEN COMPARTMENT

OPENING WITH SIDE OVERLAP

For drawers or deep drawers

LAYOUT

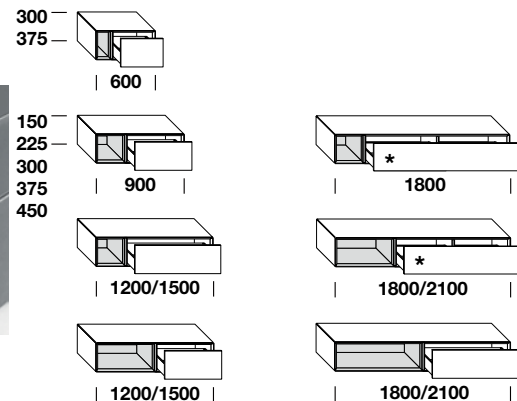
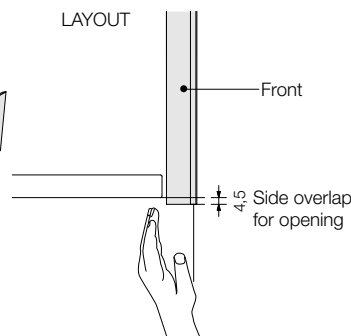
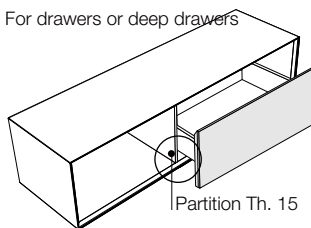

* Drawers with full front internal partition and double turn drawer

Domino Units with drawers

Technical features

DRAWER UNITS

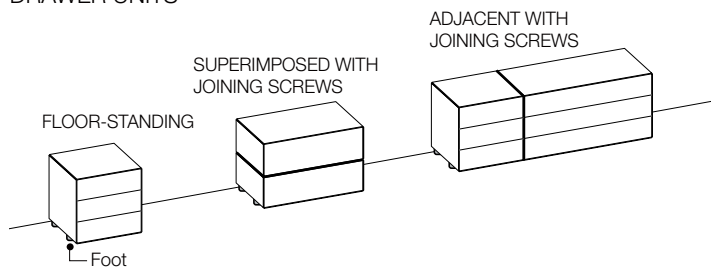

ADJUSTABLE FOOT
FROM 27 TO 45 mm

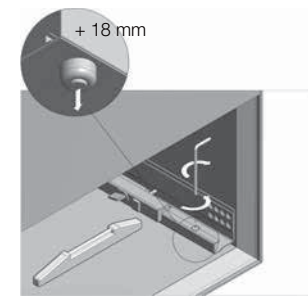

DOMINO ADJACENT DRAWER UNITS **Domino Più**

ALIGNED SUPERIMPOSED DRAWER UNITS **Domino IN**

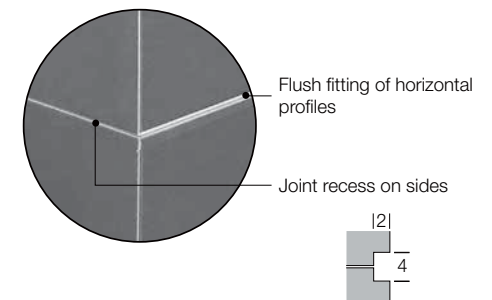
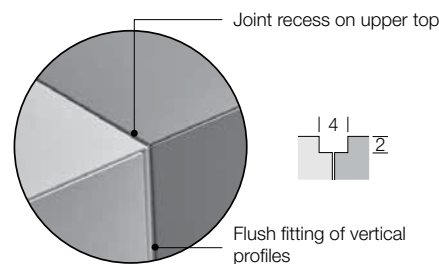
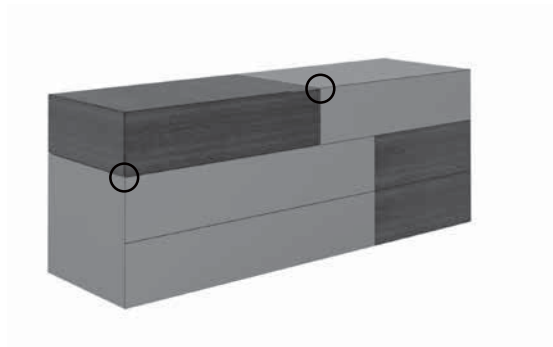

METHACRYLATE SPACER

Th. 12 for self-supporting compositions
D. 546 and 452

H 150	H 225	H 300
H 177 floor-standing	H 252 floor-standing	H 327 floor-standing

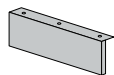

D Code

403 CYDM400

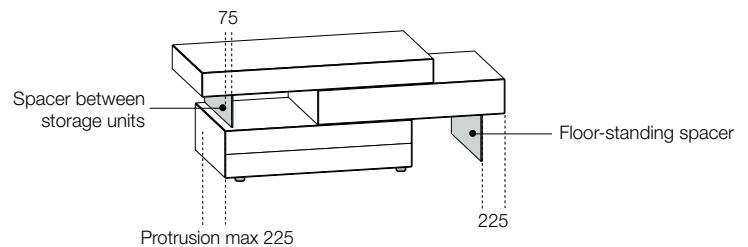
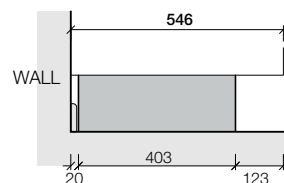
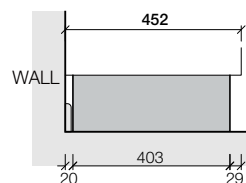

NOT ALIGNED SUPERIMPOSED DRAWER UNITS (FOR SELF-SUPPORTING COMPOSITIONS)

To ensure proper operation of the hardware, and to stop the structure from buckling, non-aligned side panels on superimposed units or internal divisions on those below or protruding on non-aligned or cantilever compositions must not exceed 225mm (Ex. 1).

Methacrylate spacers can be positioned at a max distance of 225mm from the side panels of the above units (Ex. 2) and their distance from the point at which they encounter the unit below should be no more than 900mm (Ex. 2).

Superimposed and misaligned elements are provided with non-slip rubber pads, allowing them to be positioned, within the permitted range, at the customer's discretion.

Methacrylate spacers between partitions should be placed at a distance of 75 mm or 150 mm from the sides (Ex. 3) or from internal partitions of the units below.

Compositions not within these parameters are provided with superimposed units with wall mounting hardware.

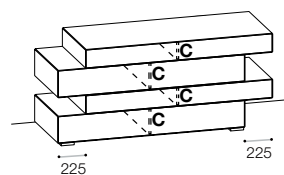

Ex. 1

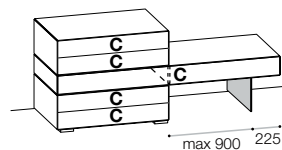

Ex. 2

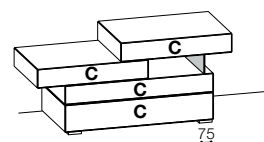

Ex. 3

Domino Units with drawers

Technical features

SOSPENDO BASE SUPPORT FOR DRAWER UNITS

Domino drawer units can be stacked and placed side by side with a metal base unit with H 150 shaped feet (type V).

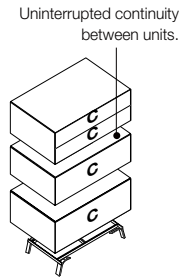
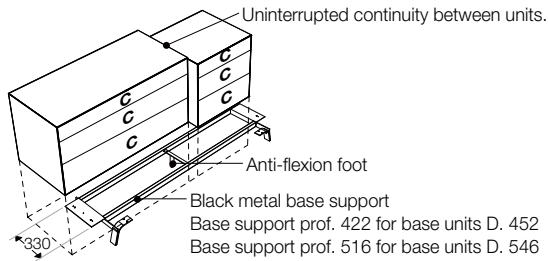

W m³ Code

Sospendo metal base support complete with feet

900	0,02	CNLC09
1200	0,03	CNLC12
1350	0,03	CNLC13
1500	0,03	CNLC15
1800	0,04	CNLC18
2100	0,05	CNLC21

Type of feet



Epoxy Metal
- Brown - Piombo - Palladio



Painted metal
- Bronzo - Ottone - Rame

266

319

281

334

288

341

265

265

311

364

329

382

OPEN WALL UNITS WITH DEPTH 352/452 BRACKETS TYPE "A"

Wall units W 300 - 375 - 450 - 600 - 900 - 1200 with full turn drawer with two brackets

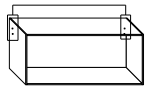

Hanging units W 1200 - 1500 - 1800 with three hangers

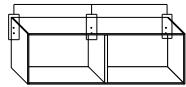

Adjacent wall units with four brackets

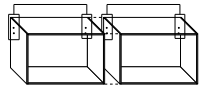

HANGER TYPE "A"

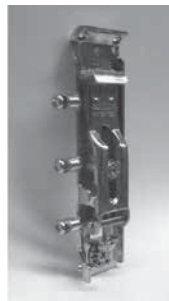

FRONT ADJUSTMENT

18 mm

VERTICAL ADJUSTMENT

25 mm

CAPACITY

Capacity
100 kg

CATAS CERTIFICATE according to the rules: LGA - DIN

Hardware section with anti-detachment system.

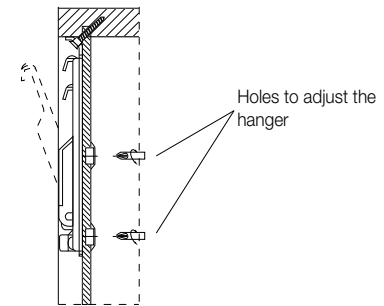

WALL UNITS WITH DEPTH 452/546 AND DRAWERS AND 546 OPEN WITH BRACKETS TYPE "B"

These hanging units are equipped with hangers for wall mounting with an innovative automatic accidental unhooking system.

Wall units W 300 - 375 - 450 - 600 - 900 - 1200 with full turn drawer with two brackets

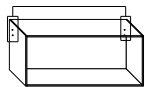

Hanging units W 1200 - 1500 - 1800 with three hangers

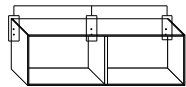

Adjacent wall units with four brackets

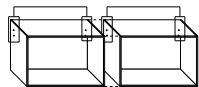

HANGER TYPE "B"

Vertical adjustment
13 mm

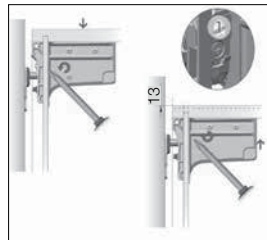

Horizontal adjustment
12 mm

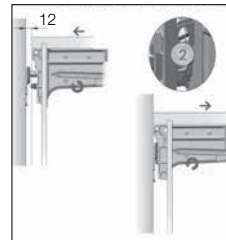

FRONT ADJUSTMENT

12 mm

VERTICAL ADJUSTMENT

13 mm

CAPACITY

120 kg

CATAS CERTIFICATE according to the rules: TÜV - LGA

ATTENTION : the capacity is related to the hardware mounted in the furniture. The given plugs for the wall mounting may not be suitable in certain situations. The responsibility concerning the assembly of the furniture belongs to the buyer, who must evaluate the resistance of his/her wall. The stability and capacity of wall-mounted elements are guaranteed by the proper assembly and by following our instructions correctly. The shelves inside the units are designed for the light loads typical of residential use (around 25 kg per square metre), distributed uniformly over the surface. For heavier or more concentrated loads, we recommend using single units with 300 - 375 - 450 - 600 mm width.

External lighting for **Domino base units with drawers**

BACK PANEL FOR SINGLE, ADJACENT, OVERLAPPED OR ON SOSPENDO BASE SUPPORT DOMINO DRAWER UNITS

The back panel is fixed to the rear of the already assembled storage unit, spacing it 19 mm from the wall.

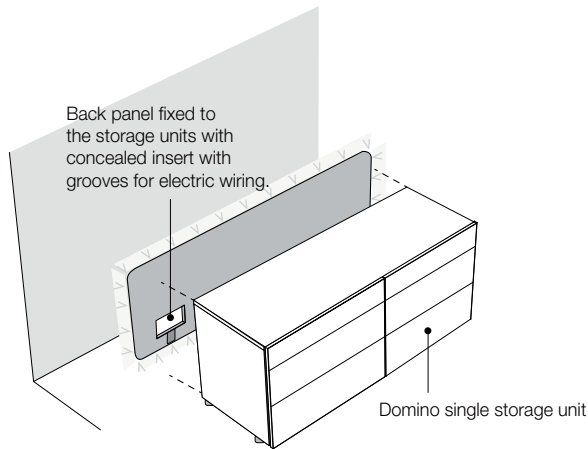

CROSS-SECTION

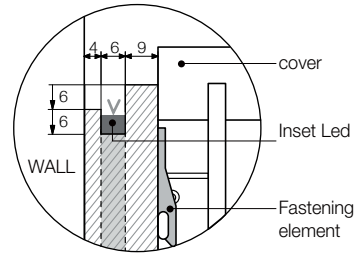

ADJACENT storage units with full frame

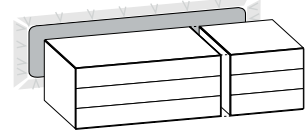

SUPERIMPOSED storage units with full frame

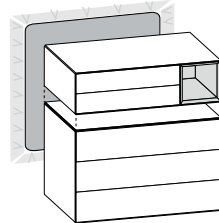

BLACK MDF BACK PANEL WITH LED

Customized heights not available. Width can be adjusted by 25mm at the price of the next size up.

If perimeters develop over more than 6m two LED systems are coupled.

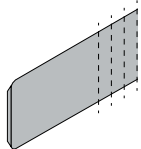

W	H	Code	Back panel WITH LED 3000K on top and sides	Max development in W	Back panel WITH LED 3000K 4 sides	Max development in W
300	From 300 to 525	CYP0305		12.54		15.22
	From 600 to 975	CYP0309		21.54		24.22
	From 1050 to 1500	CYP0315		27.54		30.22
450	From 300 to 525	CYP0405		14.04		18.22
	From 600 to 975	CYP0409		23.04		27.22
	From 1050 to 1500	CYP0415		29.04		33.22
600	From 300 to 525	CYP0605		15.54		21.22
	From 600 to 975	CYP0609		24.54		30.22
	From 1050 to 1500	CYP0615		30.54		36.22
750	From 300 to 525	CYP0704		17.54		24.22
900	From 300 to 525	CYP0905		18.54		27.22
	From 600 to 975	CYP0909		27.54		36.22
	From 1050 to 1500	CYP0915	33.54	42.22		
1200	From 300 to 525	CYP1205		21.54		33.22
	From 600 to 975	CYP1209		30.54		42.22
	From 1050 to 1500	CYP1215		36.54		48.22
1500	From 300 to 525	CYP1505		24.54		39.22
	From 600 to 975	CYP1509		33.54		48.22
1800	From 300 to 525	CYP1805		27.54		45.22
	From 600 to 975	CYP1809		36.54		54.22
2100	From 300 to 525	CYP2105		30.54		51.22
	From 600 to 975	CYP2109		39.54		60.22
2400	From 300 to 525	CYP2405		33.54		57.22
	From 600 to 975	CYP2409		42.54		66.22
2700	From 300 to 525	CYP2705		36.54		63.22
	From 600 to 975	CYP2709		45.54		72.22
3000	From 300 to 525	CYP3005		39.54		69.22
	From 600 to 975	CYP3009		48.54		78.22

Power supply max 75W already included in the price of back panel with led (with protection against overloading)

For installations and power control options see page 71

External lighting for Domino wall units D 452/352 with drawers

BLACK MDF BACK PANEL WITH PERIMETRIC INSET LED FOR HANGING SINGLE OR ADJACENT DOMINO DRAWER UNITS

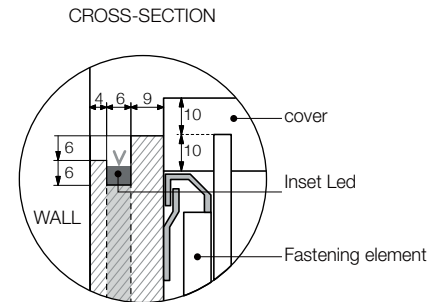
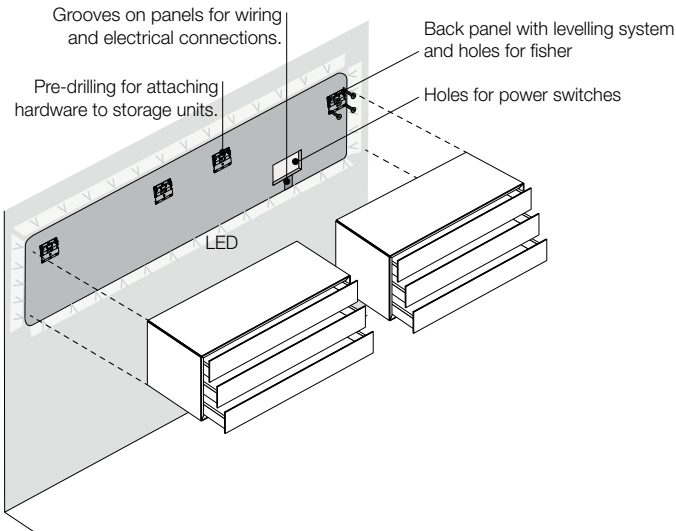

The dowels for fixing the back panel to the wall must be suitable for the material to which they are applied.

ATTENTION: the capacity of 120 kg is related to the hardware mounted in each furniture. The given plugs for the wall mounting may not be suitable in certain situations. The responsibility concerning the assembly of the furniture belongs to the buyer, who must evaluate the resistance of his/her wall. The stability and capacity of wall-mounted elements are guaranteed by the proper assembly and by following our instructions correctly.

BACK PANEL COMPLETE WITH LED

Customized heights not available. Width can be adjusted by 25mm at the price of the next size up.

If perimeters develop over more than 6m two LED systems are coupled.

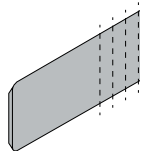

	W	H	Code	Back panel WITH LED 3000K on top and sides	Max development in W	Back panel WITH LED 3000K 4 sides	Max development in W
300		From 300 to 525	CYR0305		12.54		15.22
		From 600 to 900	CYR0309		20.04		22.72
		From 1200 to 1500	CYR0315		32.04		34.72
450		From 300 to 525	CYR0405		14.04		18.22
		From 600 to 900	CYR0409		21.54		25.72
		From 1200 to 1500	CYR0415		33.54		37.72
600		From 300 to 525	CYR0605		15.54		21.22
		From 600 to 900	CYR0609		23.04		28.72
		From 1200 to 1500	CYR0615		35.04		40.72
750		From 300 to 450	CYR0704		15.54		22.72
	600	From 300 to 525	CYR0905		18.54		27.22
		From 600 to 900	CYR0909		26.04		34.72
		From 1200 to 1500	CYR0915	38.04	46.72		
1200		From 300 to 525	CYR1205		21.54		33.22
		From 600 to 900	CYR1209		29.04		40.72
		From 1200 to 1500	CYR1215		41.04		52.72
1500		From 300 to 450	CYR1504		23.04		37.72
			CYR1506		26.04		40.72
1800		From 300 to 450	CYR1804		26.04		43.72
			CYR1806		29.04		46.72
2100		From 300 to 450	CYR2104		29.04		49.72
			CYR2106		32.04		52.72
2400		From 300 to 450	CYR2404		32.04		55.72
			CYR2406		35.04		58.72
2700		From 300 to 450	CYR2704		35.04		61.72
			CYR2706		38.04		64.72
3000		From 300 to 450	CYR3004		38.04		67.72
			CYR3006		41.04		70.72

Power supply max 75W already included in the price of back panel with led (with protection against overloading)

For installations and power control options see page 71